



# PETROWORKS

## OFF-ROAD PRODUCTS

[www.petroworks.com](http://www.petroworks.com)

### Front Axle Figure 47

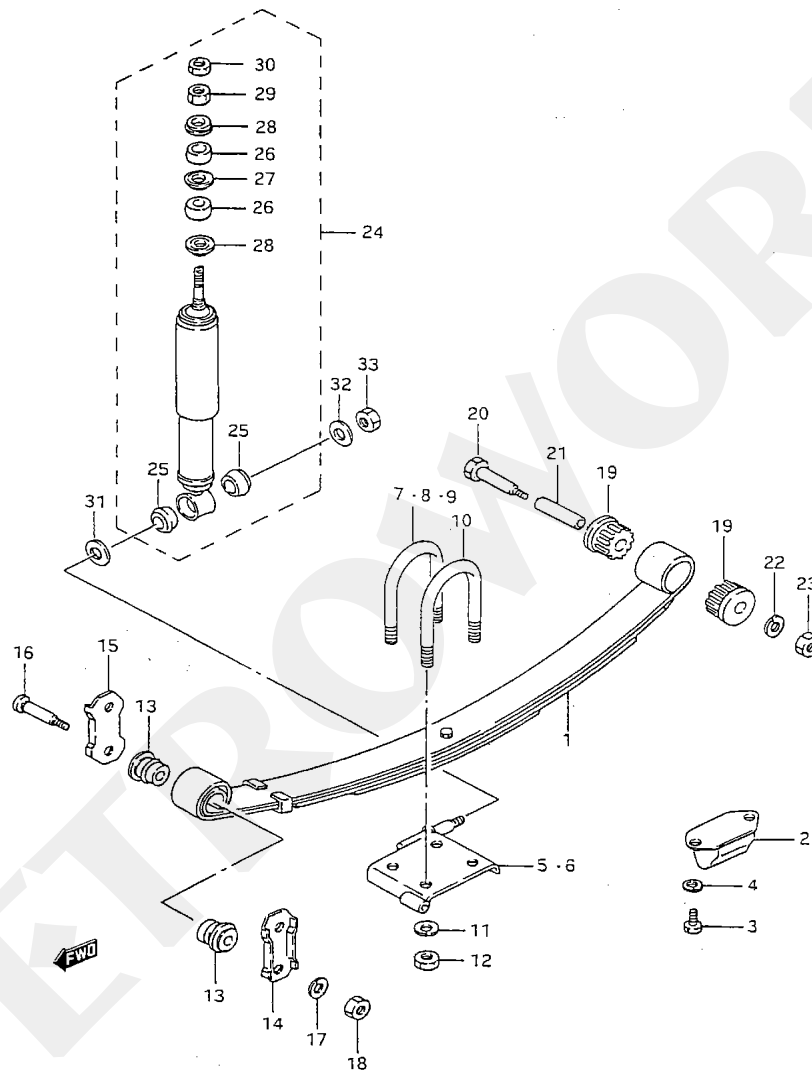

SAMURAI E33

#### Technical Note:

When trying to do a minor lift you should not put any shackle on that is 2" longer than stock. This will throw off the camber on the front end and give the car a death wobble. Also off road they will act like a set of fangs catching everything on the trail.

[Replacement Stock Shackles Spring Bushings](#)

[Heavy Duty 2" Shackles](#)

[For a minor lift and an Awesome ride check out the Old Man EMU Springs](#)