



PETROWORKS

OFF-ROAD PRODUCTS

www.petroworks.com

Transfer Case Breakdown Figure 29

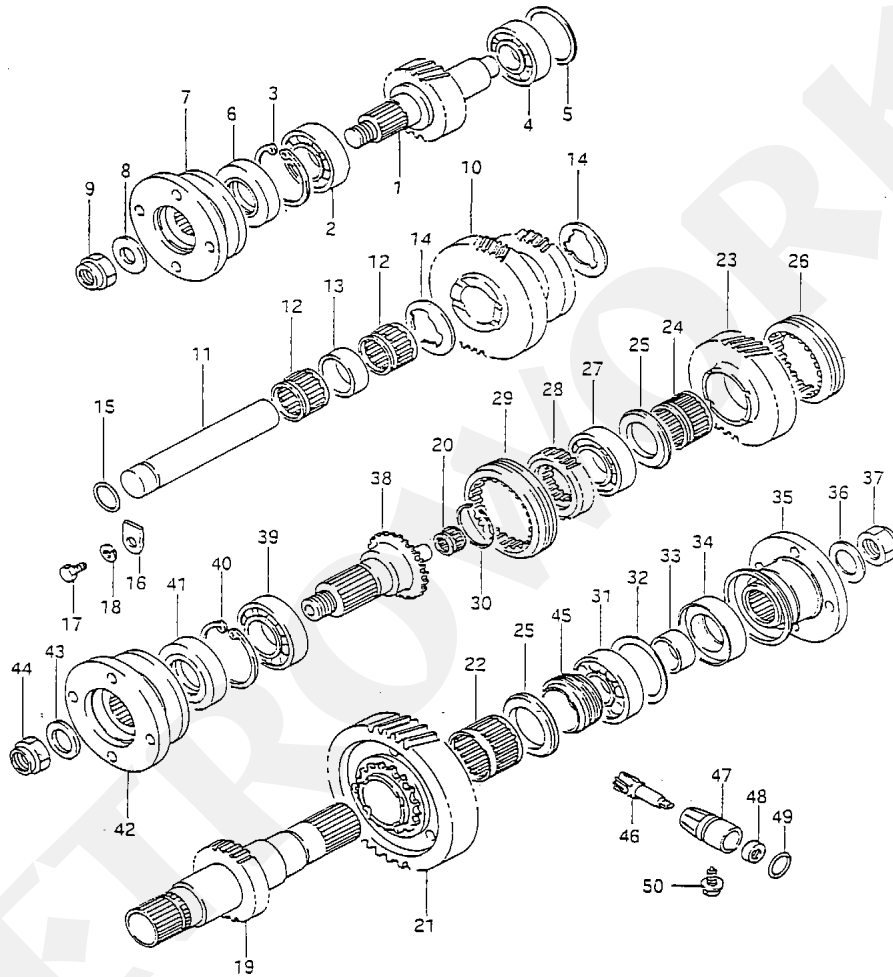

 SAMURAI E33

For Cars running larger tires it is important to either change out the Differential Gears or the Transfer Case Gears to regain lost power, and prevent premature burning up of the clutch, and for added control while offroad. Petroworks offers complete rebuild kits and individual components for the transfer case.